

**1. Automatic Transmission and Differential**

**A: SPECIFICATIONS**

Torque converter clutch	Type		Symmetric, 3 element, single stage, 2 phase torque converter		
	Stall torque ratio	2200 cc	2.0 — 2.2		
		2500 cc	1.9 — 2.1		
	Nominal diameter	2200 cc	236 mm (9.29 in)		
		2500 cc	246 mm (9.69 in)		
	Stall speed (at sea level)	2200 cc	2,200 — 2,700 rpm		
2500 cc		2,100 — 2,600 rpm			
One-way clutch			Sprague type one-way clutch		
Automatic transmission	Transmission	Type	4-forward, 1-reverse, double-row planetary gears		
		Control element	Multi-plate clutch		3 sets
			Multi-plate brake		2 sets
			One-way clutch (sprague type)		1 set
		Gear ratio	1st	2200 cc	2.785
				2500 cc	3.027
			2nd	2200 cc	1.545
				2500 cc	1.619
			3rd		1.000
			4th		0.694
			Reverse		2.272
		Tooth number of planetary gear	Front sun gear		33
			Front pinion		21
			Front internal gear		75
			Rear sun gear	2200 cc	42
				2500 cc	37
			Rear pinion	2200 cc	17
				2500 cc	19
			Rear internal gear		75
		Plate number of high clutch	Drive plate & driven plate	2200 cc	4
2500 cc	5				
Plate number of reverse clutch	Drive plate & driven plate		2		
Plate number of 2-4 brake	Drive plate & driven plate		3		
Plate number of low clutch	Drive plate & driven plate	2200 cc	5		
		2500 cc	6		
Plate number of low & reverse brake	Drive plate & driven plate	2200 cc	5		
		2500 cc	6		

# SPECIFICATIONS AND SERVICE DATA

[S1A0] 3-2













## 1. Automatic Transmission and Differential

Automatic transmission	Transmission	Selector position		P (Park)	Transmission in neutral, output member immovable, and engine start possible	
				R (Reverse)	Transmission in reverse for backing	
				N (Neutral)	Transmission in neutral, and engine start possible	
				D (Drive)	Automatic gear change 1st ← → 2nd ← → 3rd ← → 4th	
				3 (3rd)	Automatic gear change 1st ← → 2nd ← → 3rd ← 4th	
				2 (2nd)	2nd gear locked (Deceleration possible 4th → 3rd → 2nd)	
				1 (1st)	1st gear locked (Deceleration possible 4th → 3rd → 2nd → 1st)	
				Control method		Hydraulic remote control
	Oil pump	Type		Prachoid constant-displacement pump		
		Driving method		Driven by engine		
		Number of teeth		Inner rotor	9	
				Outer rotor	10	
	Hydraulic control	Type		Electronic/hydraulic control [Four forward speed changes by electrical signals of vehicle speed and accelerator (throttle) opening]		
		Fluid		Dexron IIE or Dexron III type Automatic transmission fluid		
		Fluid capacity		2200 cc	8.4 — 8.7 ℓ (8.9 — 9.2 US qt, 7.4 — 7.7 Imp qt)	
				2500 cc	9.3 — 9.6 ℓ (9.8 — 10.1 US qt, 8.2 — 8.4 Imp qt)	
	Lubrication	Lubrication system		Forced feed lubrication with oil pump		
		Oil		Automatic transmission fluid (above mentioned.)		
	Cooling	Cooling system		Liquid-cooled cooler incorporated in radiator		
	Harness	Inhibitor switch		12 poles		
		Transmission harness		17 poles		
	Transfer	Transfer clutch		Hydraulic multi-plate clutch		
		Plate number of transfer clutch		Drive plate & driven plate	5	
		Control method		Electronic, hydraulic type		
		Lubricant		The same Automatic Transmission Fluid used in automatic transmission.		
		1st reduction gear ratio		1.000 (53/53)		

### 3-2 [S1A0]

## SPECIFICATIONS AND SERVICE DATA

### 1. Automatic Transmission and Differential

Final reduction	Final gear ratio	Front drive	2200 cc	4.111 (37/9)														
			2500 cc	4.444 (40/9)														
	Lubrication oil	<p style="text-align: center;">ITEM</p> <p style="text-align: center;">• Front differential gear oil</p> <p style="text-align: center;">API Classification</p> <p style="text-align: center;">GL - 5</p> <table border="1" style="width: 100%; border-collapse: collapse;"> <thead> <tr> <th colspan="2">SAE Viscosity No. and Applicable Temperature</th> </tr> <tr> <th>(°C)</th> <th>-30 -26 -15 -5 0 15 25 30</th> </tr> <tr> <th>(°F)</th> <th>-22 -15 5 23 32 59 77 86</th> </tr> </thead> <tbody> <tr> <td style="text-align: center;">90</td> <td style="text-align: center;">  </td> </tr> <tr> <td style="text-align: center;">85W</td> <td style="text-align: center;">  </td> </tr> <tr> <td style="text-align: center;">80W</td> <td style="text-align: center;">  </td> </tr> <tr> <td style="text-align: center;">80W-90</td> <td style="text-align: center;">  </td> </tr> </tbody> </table>			SAE Viscosity No. and Applicable Temperature		(°C)	-30 -26 -15 -5 0 15 25 30	(°F)	-22 -15 5 23 32 59 77 86	90		85W		80W		80W-90	
	SAE Viscosity No. and Applicable Temperature																	
	(°C)	-30 -26 -15 -5 0 15 25 30																
(°F)	-22 -15 5 23 32 59 77 86																	
90																		
85W																		
80W																		
80W-90																		
Oil capacity	Front drive	1.2 ℓ (1.3 US qt, 1.1 Imp qt)																
ATF cooling system	Radiation capacity	4.630 kW (3,981 kcal/h, 15,797 BTU/h)																

H3M1235A

**MEMO:**

**B: ADJUSTING PARTS**

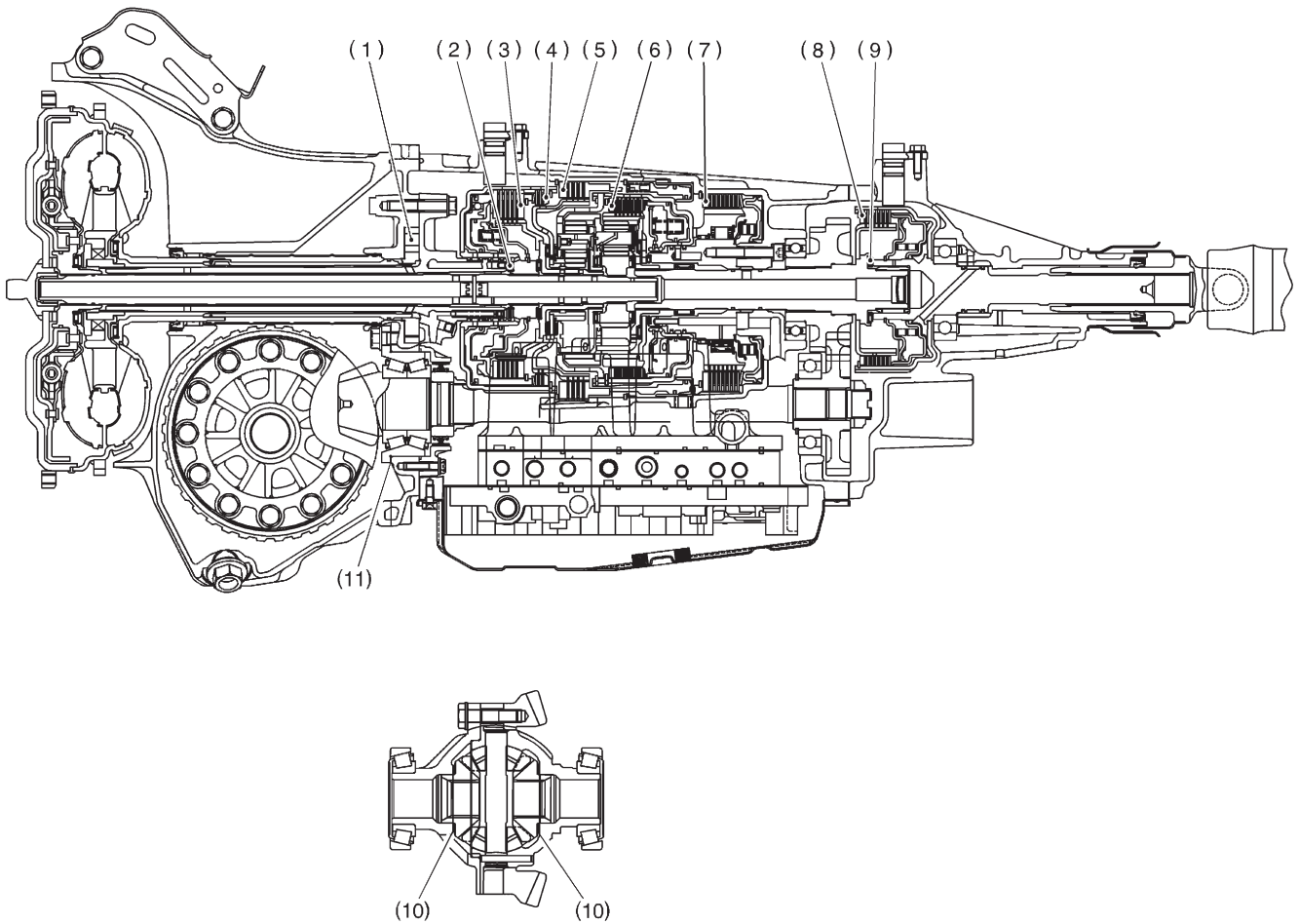

# SPECIFICATIONS AND SERVICE DATA

[S1B0] 3-2

## 1. Automatic Transmission and Differential

No.	Part Name	Part Number	Dimension mm (in)	Application
1	Rotor (Oil pump)	15008AA060 15008AA070 15008AA080	11.37 — 11.38 (0.4476 — 0.4480) 11.38 — 11.39 (0.4480 — 0.4484) 11.39 — 11.40 (0.4484 — 0.4488)	Adjusting side clearance of oil pump
2	Thrust bearing	806528050 806528060 806528070 806528080 806528090 806528100	4.11 (0.1618) 4.3 (0.169) 4.5 (0.177) 4.7 (0.185) 4.9 (0.193) 5.1 (0.201)	Adjusting total end play
3	Retaining plate (High clutch)	31567AA710 31567AA720 31567AA730 31567AA740 31567AA670 31567AA680 31567AA690 31567AA700	4.7 (0.185) 4.8 (0.189) 4.9 (0.193) 5.0 (0.197) 5.1 (0.201) 5.2 (0.205) 5.3 (0.209) 5.4 (0.213)	Adjusting clearance of high clutch
4	Retaining plate (Reverse clutch)	31567AA750 31567AA760 31567AA770 31567AA780 31567AA790 31567AA800 31567AA810 31567AA820	3.8 (0.150) 4.0 (0.157) 4.2 (0.165) 4.4 (0.173) 4.6 (0.181) 4.8 (0.189) 5.0 (0.197) 5.2 (0.205)	Adjusting clearance of reverse clutch
5	Retaining plate (2-4 brake)	31567AA612 31567AA622 31567AA632 31567AA642 31567AA652 31567AA662	5.6 (0.220) 5.8 (0.228) 6.0 (0.236) 6.2 (0.244) 6.4 (0.252) 6.6 (0.260)	Adjusting clearance of 2-4 brake
6	Retaining plate (Low clutch)	31567AA830 31567AA840 31567AA850 31567AA860 31567AA870	3.8 (0.150) 4.0 (0.157) 4.2 (0.165) 4.4 (0.173) 4.6 (0.181)	Adjusting clearance of low clutch
7	Retaining plate (Low and reverse brake)	31667AA320 31667AA330 31667AA340 31667AA350 31667AA360 31667AA370 31667AA380	4.2 (0.165) 4.5 (0.177) 4.8 (0.189) 5.1 (0.201) 5.4 (0.213) 5.7 (0.224) 6.0 (0.236)	Adjusting clearance of low and reverse brake
8	Pressure plate (Transfer clutch)	31593AA151 31593AA161 31593AA171 31593AA181	3.3 (0.130) 3.7 (0.146) 4.1 (0.161) 4.5 (0.177)	Adjusting clearance of transfer clutch
9	Thrust bearing (Transfer clutch)	806536020 806535030 806535040 806535050 806535060 806535070 806535090	3.8 (0.150) 4.0 (0.157) 4.2 (0.165) 4.4 (0.173) 4.6 (0.181) 4.8 (0.189) 5.0 (0.197)	Adjusting end play of transfer clutch
10	Washer (Front differential)	803038021 803038022 803038023	0.95 (0.0374) 1.00 (0.0394) 1.05 (0.0413)	Adjusting backlash of differential bevel gear

**3-2 [S1B0]****SPECIFICATIONS AND SERVICE DATA**1. Automatic Transmission and Differential

---

No.	Part Name	Part Number	Dimension mm (in)	Application
11	Drive pinion shim	31451AA050	0.150 (0.0059)	Adjusting drive pinion shim
		31451AA060	0.175 (0.0069)	
		31451AA070	0.200 (0.0079)	
		31451AA080	0.225 (0.0089)	
		31451AA090	0.250 (0.0098)	
		31451AA100	0.275 (0.0108)	

**MEMO:**



C: LOCATION AND INSTALLING DIRECTION OF THRUST NEEDLE BEARING

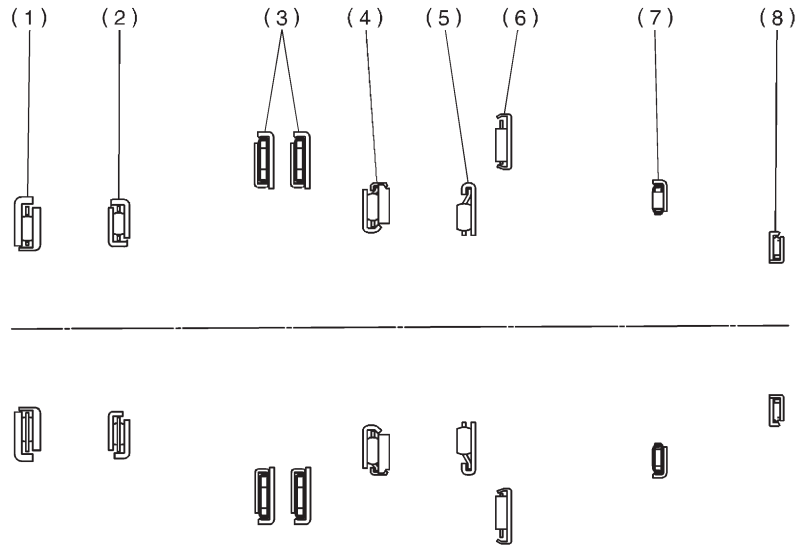
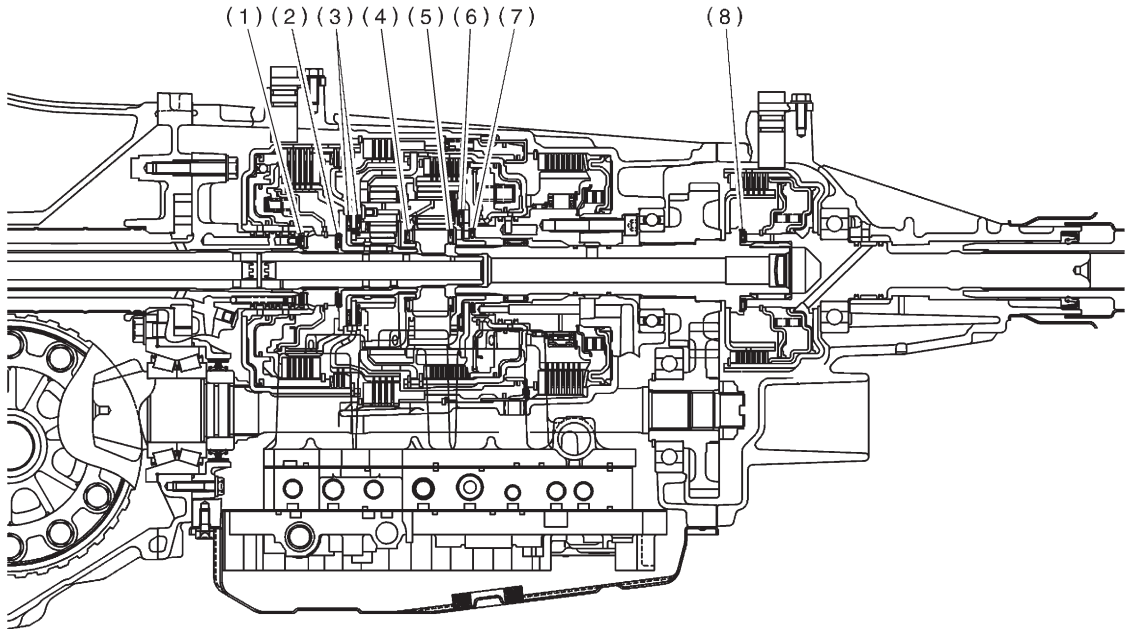

# SPECIFICATIONS AND SERVICE DATA

[S1D1] 3-2

## 1. Automatic Transmission and Differential

No.	Part Name	Part Number	Inside diameter mm (in)	Outside diameter mm (in)	Dimension mm (in)	Application
(1)	Thrust needle bearing	806528050 806528060 806528070 806528080 806528090 806528100	28.5 (1.122)	48 (1.89)	4.11 (0.1618) 4.3 (0.169) 4.5 (0.177) 4.7 (0.185) 4.9 (0.193) 5.1 (0.201)	Adjusting total end play
(2)	Thrust needle bearing	806530040	30 (1.18)	47 (1.85)	3.8 (0.150)	Place of high clutch
(3)	Thrust needle bearing	806551020	51 (2.01)	71 (2.80)	3.3 (0.130)	Place of front sun gear
(4)	Thrust needle bearing	806535120	35 (1.38)	53 (2.09)	4.8 (0.189)	Place of rear sun gear
(5)	Thrust needle bearing	806534060	35 (1.38)	53 (2.09)	3.3 (0.130)	Place of rear sun gear
(6)	Thrust needle bearing	806558030	58 (2.28)	78 (3.07)	2.8 (0.110)	Place of rear internal gear
(7)	Thrust needle bearing	806541020	39.7 (1.563)	54 (2.13)	3.6 (0.142)	Place of one-way clutch
(8)	Thrust needle bearing	806536020 806535030 806535040 806535050 806535060 806535070 806535090	36 (1.42)	53 (2.09)	3.8 (0.150) 4.0 (0.157) 4.2 (0.165) 4.4 (0.173) 4.6 (0.181) 4.8 (0.189) 5.0 (0.197)	Adjusting end play of transfer clutch

## D: FLUID PASSAGES

### 1. TRANSMISSION CASE (FRONT SIDE)

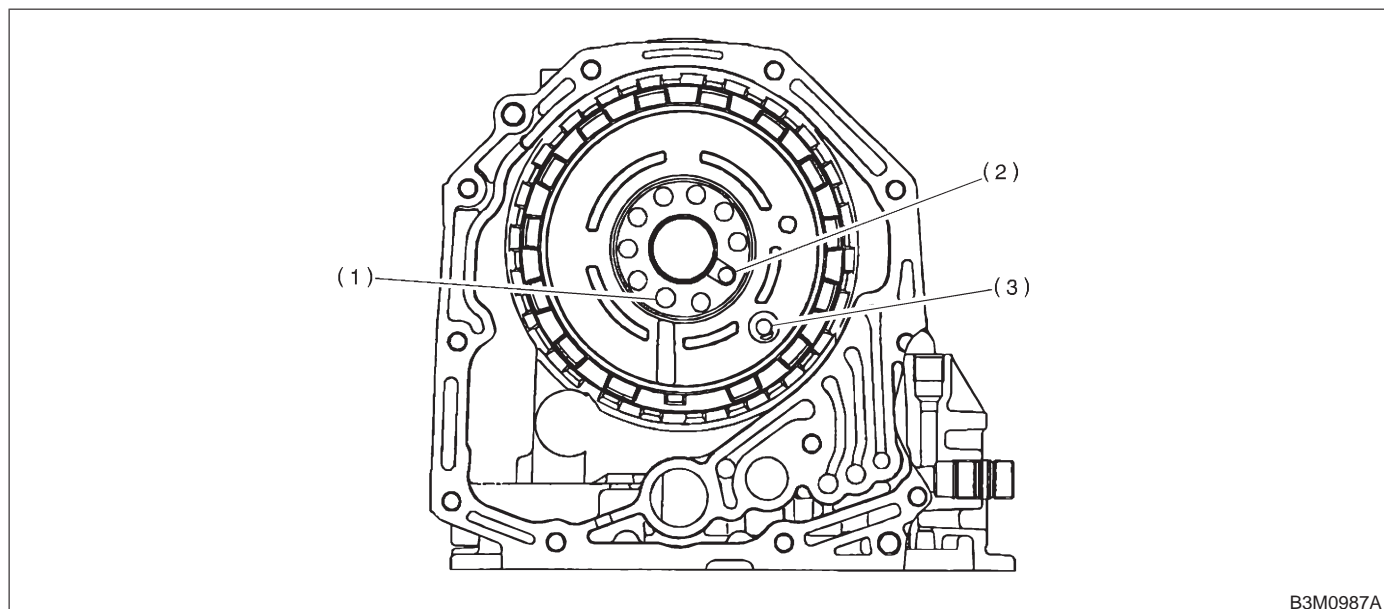

B3M0987A

(1) Low clutch pressure

(2) Oil cooler inlet pressure

(3) Low & reverse brake pressure

### 3-2 [S1D2]

## SPECIFICATIONS AND SERVICE DATA

### 1. Automatic Transmission and Differential

#### 2. TRANSMISSION CASE (LH SIDE)

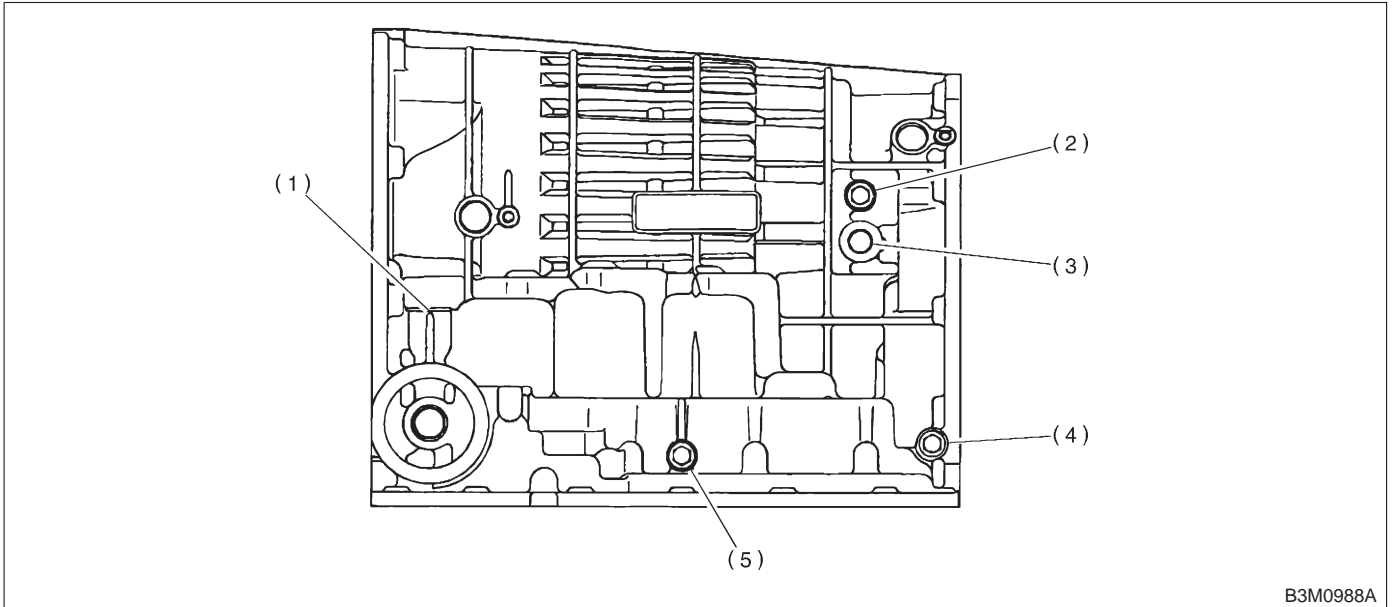

B3M0988A

- |                                  |                               |                        |
|----------------------------------|-------------------------------|------------------------|
| (1) Oil cooler outlet pressure   | (3) Oil cooler inlet pressure | (5) 2-4 brake pressure |
| (2) Low & reverse brake pressure | (4) Low clutch pressure       |                        |

#### 3. TRANSMISSION CASE (REAR SIDE)

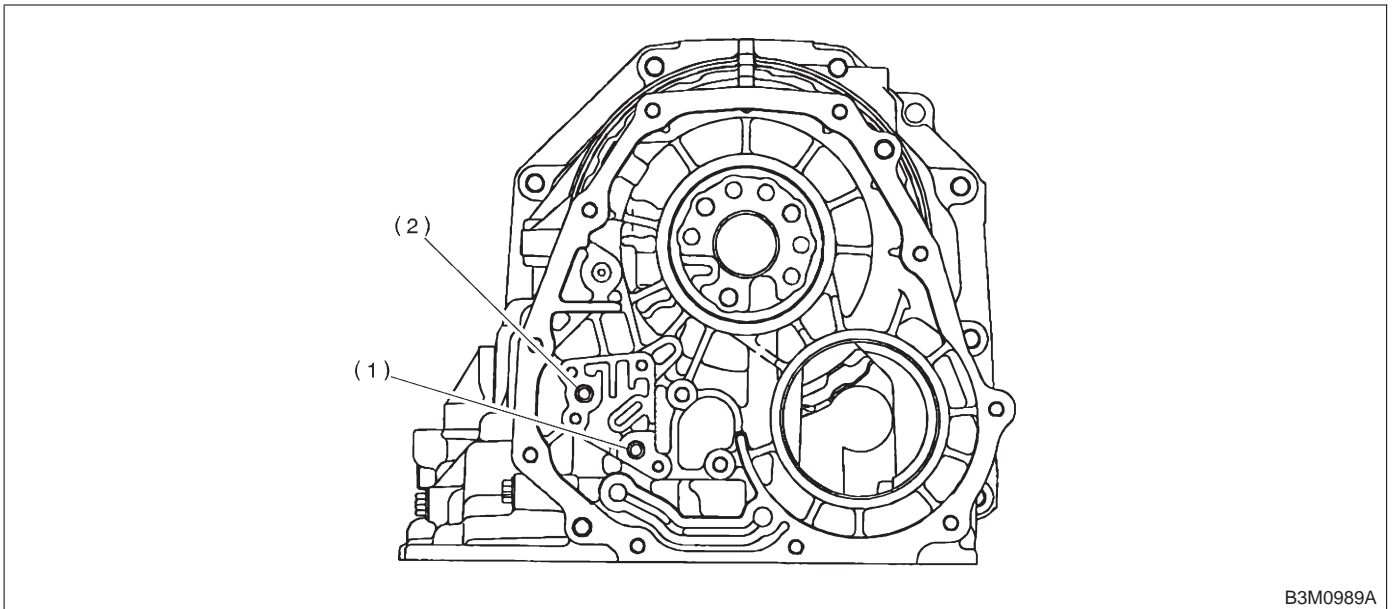

B3M0989A

- |                    |                   |
|--------------------|-------------------|
| (1) Pilot pressure | (2) Line pressure |
|--------------------|-------------------|

**4. OIL PUMP COVER**

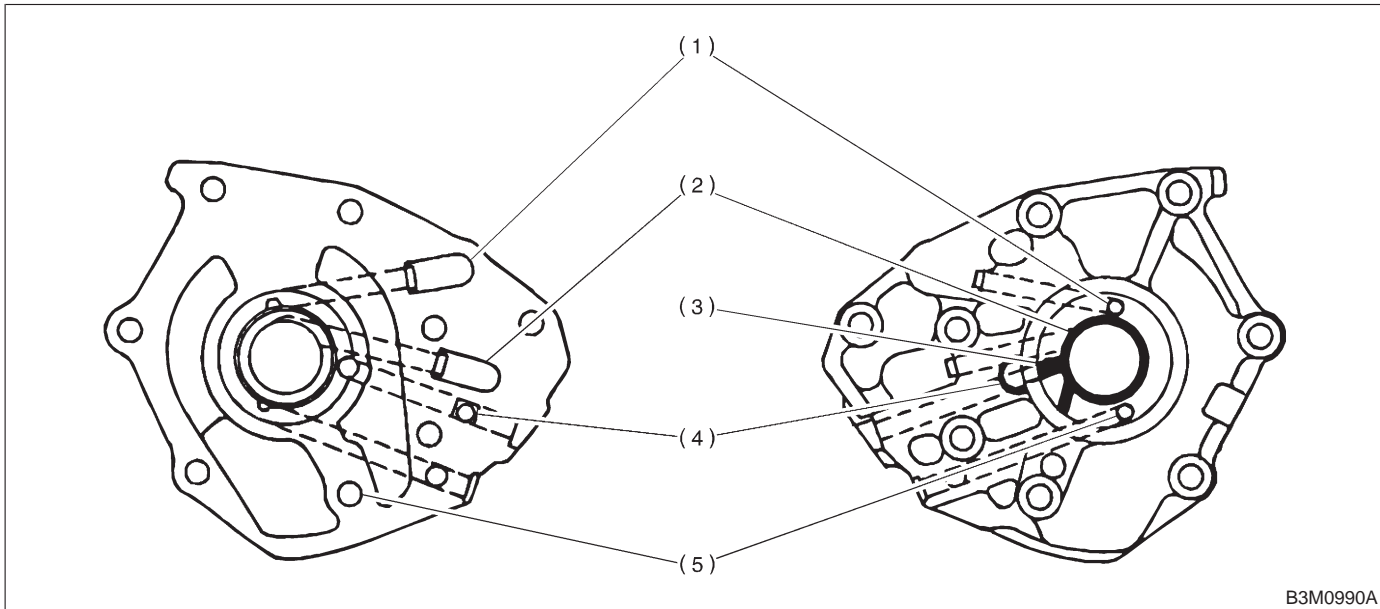

B3M0990A

- |                              |                            |                             |
|------------------------------|----------------------------|-----------------------------|
| (1) High clutch pressure     | (3) Front lubricating hole | (5) Reverse clutch pressure |
| (2) Lock-up release pressure | (4) Lock-up apply pressure |                             |

**5. OIL PUMP HOUSING**

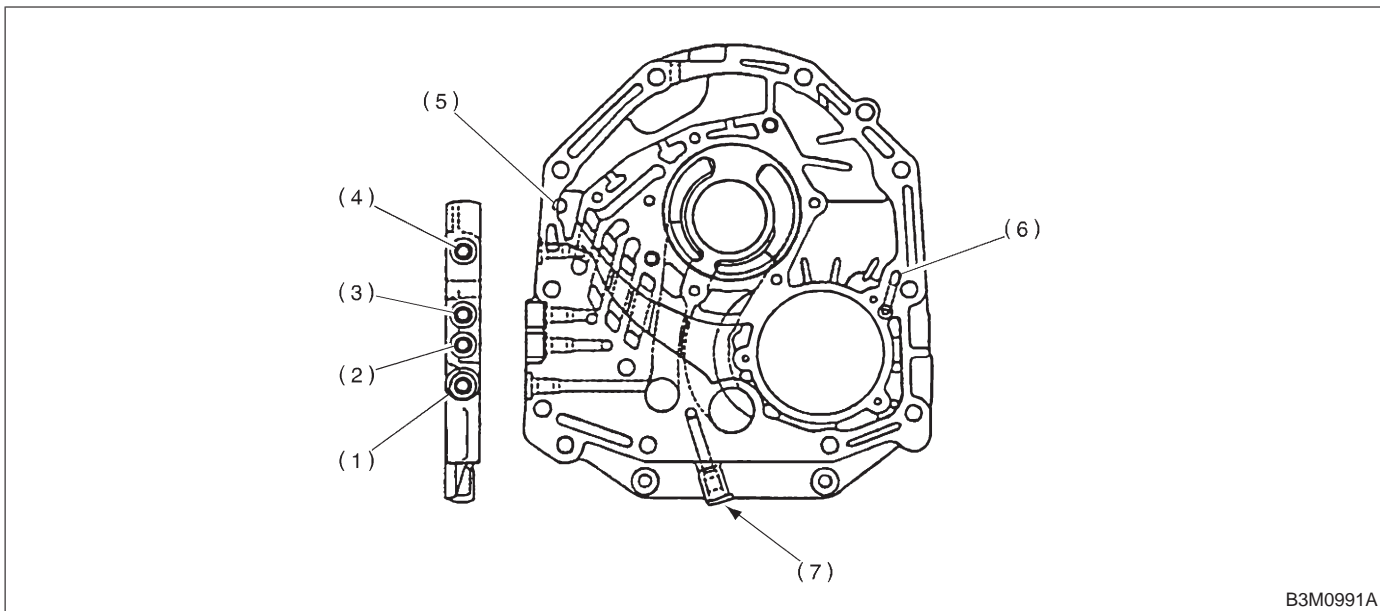

B3M0991A

- |                              |                          |                             |
|------------------------------|--------------------------|-----------------------------|
| (1) Oil pump outlet pressure | (4) High clutch pressure | (7) Reverse clutch pressure |
| (2) Lock-up apply pressure   | (5) Drain                |                             |
| (3) Lock-up release pressure | (6) Air breather         |                             |

**6. TRANSMISSION CASE**

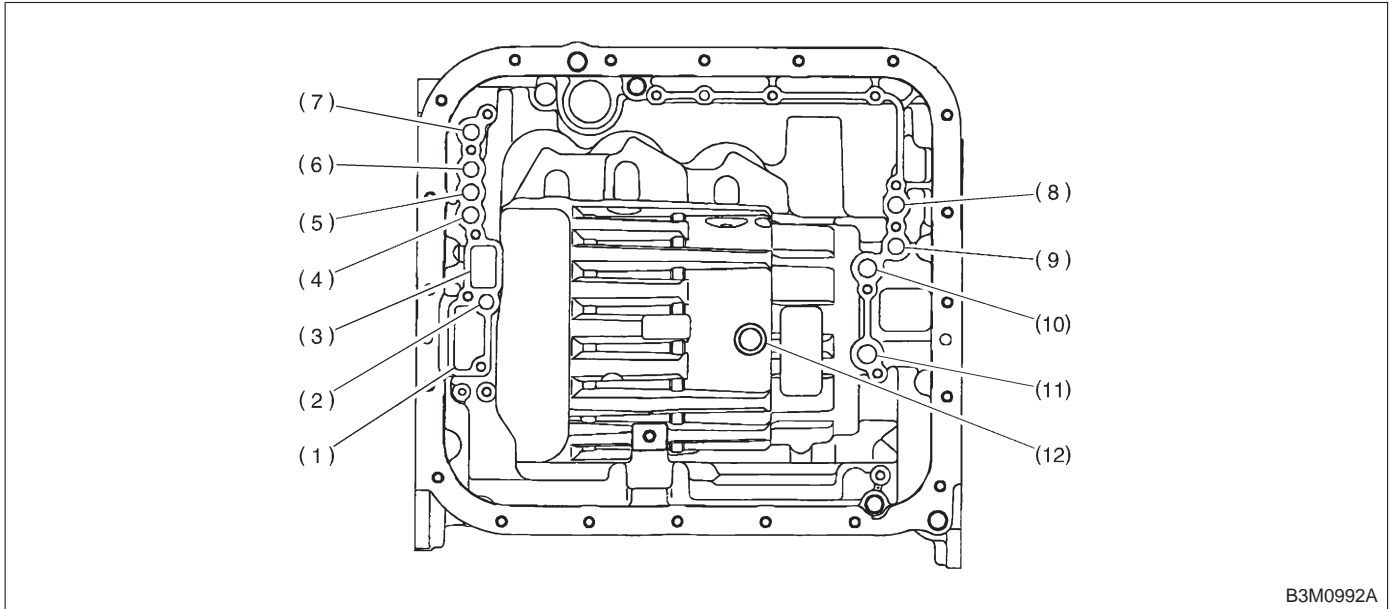

B3M0992A

- |                             |                                |                                   |
|-----------------------------|--------------------------------|-----------------------------------|
| (1) Oil pump inlet port     | (5) Lock-up release pressure   | (9) Pilot pressure                |
| (2) Reverse clutch pressure | (6) High clutch pressure       | (10) Low & reverse brake pressure |
| (3) Oil pump outlet port    | (7) Oil cooler outlet pressure | (11) Low clutch pressure          |
| (4) Lock-up apply pressure  | (8) Line pressure              | (12) 2-4 brake pressure           |

**7. EXTENSION CASE**

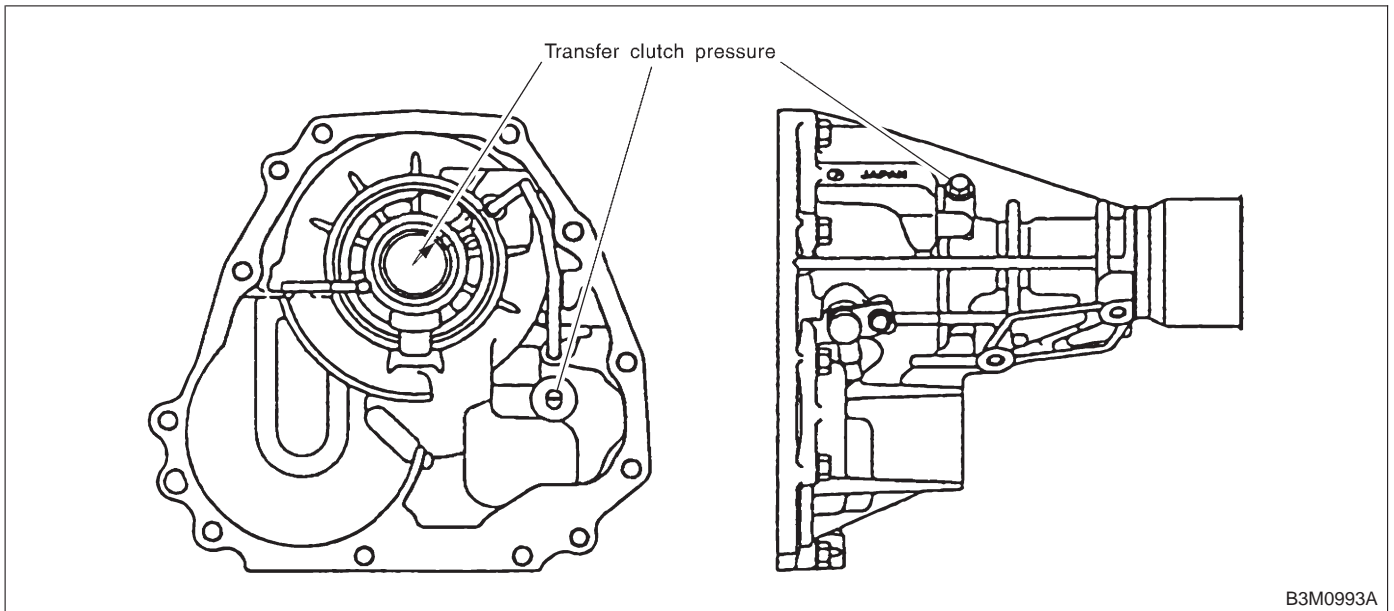

B3M0993A